



Wireless 150 Amp AC Current Meters

General Description

The wireless AC Current Meter measures the RMS current of an alternating current (AC) system using a current transformer (CT) that wraps around the "hot" wire of a two wire (hot, common, ground(optional)) power system. The sensor reports Minimum RMS current, maximum RMS current, average RMS current, and amp hours to the system. The system is capable of generating watt hour or kilowatt hour readings as well.

- Measures amp hours, max RMS current, min RMS current, and average RMS current
- Two different current transducers available:
 - Low Current: 0-20 amp
 - High Current: 0-150 amp
- Capable of generating watt hour or kilowatt hour readings using the portal
- Data logging for accumulated amp hour readings
- Can notify based on current levels or changes in current levels
- Simple and safe installation of current/power measurement hardware, no rewiring required

Principle of Operation

To measure current, clip the CT around only a single wire of the AC system (clipping around a hot and neutral wire at the same time will result in 0 current readings). After the sensor powers on and connects to the gateway it will begin taking measurements based on the averaging interval (5 seconds default). It will report data to every heartbeat or if the current goes outside of the aware thresholds set in the portal. The sensor reports amp hours, max RMS current, min RMS current, and average RMS current. the potral can also generate watt hour or kilowatt hour readings if a default RMS voltage is set in the portal.

Example Interfacing

- Current monitoring
- Amperage monitoring
- Current usage
- Amp hour meter

Features of Sensors

- Wireless range of 1,200+ feet through 12+ walls *
- Frequency-Hopping Spread Spectrum (FHSS)
- Improved interference immunity
- Improved power management for longer battery life ** (12+ years on AA batteries)
- Encrypt-RF® Security (Diffie-Hellman Key Exchange + AES-128 CBC for sensor data messages)
- All sensors now have up to 3200 readings:
 - 10-minute heartbeats = 22 days
 - 2-hour heartbeats = 266 days
- Over-the-air updates (future proof)
- Online wireless sensor monitoring and notification system to configure sensors, view data and set alerts via SMS text and email

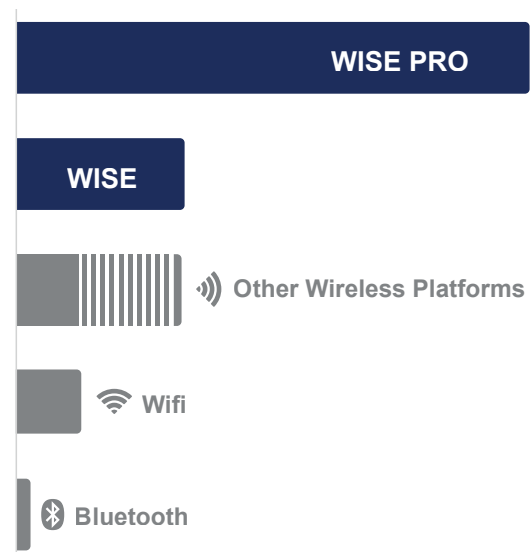

* Actual range may vary depending on environment.
 ** Battery life is determined by sensor reporting frequency and other variables. Other power options are also available.

Wireless Range Comparison

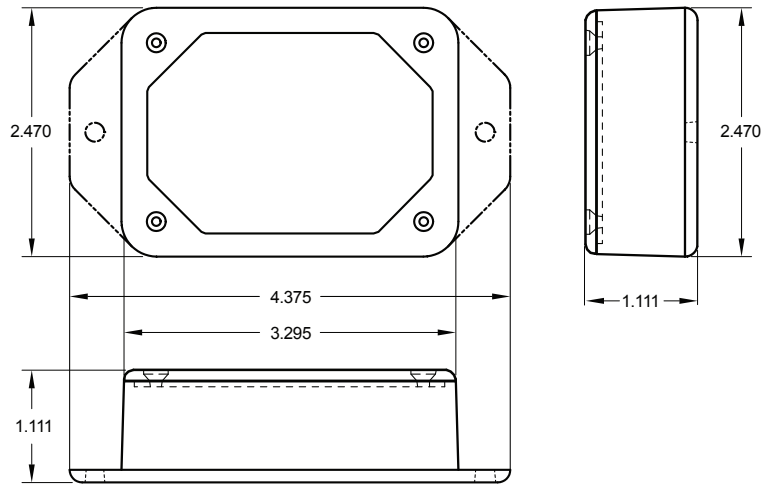





Commercial AA Wireless AC Current Meter | Technical Specifications

Supply voltage	2.0–3.8 VDC (3.0–3.8 VDC using power supply) *
Current consumption	0.2 μ A (sleep mode), 0.7 μ A (RTC sleep), 570 μ A (MCU idle), 2.5 mA (MCU active), 5.5 mA (radio RX mode), 22.6 mA (radio TX mode)
Operating temperature range (board circuitry and batteries)	-18°C to 55°C (0°F to 130°F) using alkaline -40°C to 85°C (-40°F to 185°F) using lithium **
Optimal battery temperature range (AA)	+10°C to +50°C (+50°F to +122°F)
Integrated memory	Up to 3200 sensor messages
Wireless range	1,200+ ft non-line-of-sight
Security	Encrypt-RF® (256-bit key exchange and AES-128 CTR)
Weight	3.7 ounces
Certifications	<div style="display: flex; align-items: center; gap: 10px;">   Industry Canada </div> 900 MHz product; FCC ID: ZTL-G2SC1 and IC: 9794A-G2SC1. 868 and 433 MHz product tested and found to comply with: EN 300 220-2 V3.1.1 (2017-02), EN 300 220-2 V3.1.1 (2017-02) and EN 60950

* Hardware cannot withstand negative voltage. Please take care when connecting a power device.

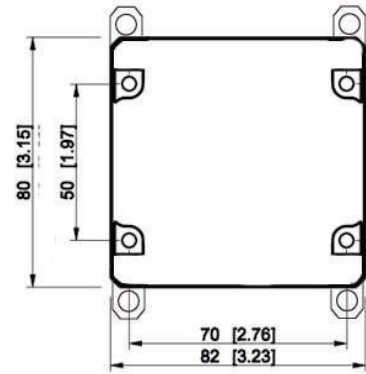
** At temperatures above 100°C, it is possible for the board circuitry to lose programmed memory.



Industrial Wireless AC Current Meter Technical Specifications		
Supply voltage	2.0–3.8 VDC (3.0–3.8 VDC using power supply) *	
Current consumption	0.2 μ A (sleep mode), 0.7 μ A (RTC sleep), 570 μ A (MCU idle), 2.5 mA (MCU active), 5.5 mA (radio RX mode), 22.6 mA (radio TX mode)	
Operating temperature range (board circuitry and battery)	-40°C to +85°C (-40°F to +185°F) **	
Included battery	Max temperature range	-40° to +85°C (-40° to +185°F)
	Capacity	1500 mAh
Optional solar feature	Solar panel	5VDC/30mA (53mm x 30mm)
	Charging temperature range	0° to 45°C (32° to 113°F)
	Max temperature range	-20° to 60°C (-4° to 140°F)
	Included rechargeable battery	600 mAh/>2000 charge cycles (80% of initial capacity)
	Solar efficiency	Optimized for high and low-light operation ***
Integrated memory	Up to 3200 sensor messages	
Wireless range	1,200+ ft non-line-of-sight	
Security	Encrypt-RF® (256-bit key exchange and AES-128 CTR)	
Weight	4.7 ounces	
Enclosure rating	NEMA 1, 2, 4, 4x, 12 and 13 rated, sealed and weather proof	
UL rating	UL Listed to UL508-4x specifications (File E194432)	
Certifications	<div style="display: flex; align-items: center; gap: 10px;">   Industry Canada </div> 900 MHz product; FCC ID: ZTL-G2SC1 and IC: 9794A-G2SC1. 868 and 433 MHz product tested and found to comply with: EN 300 220-2 V3.1.1 (2017-02), EN 300 220-2 V3.1.1 (2017-02) and EN 60950	

* Hardware cannot withstand negative voltage. Please take care when connecting a power device.

** At temperatures above 100°C, it is possible for the board circuitry to lose programmed memory. Light present 25% of day yields 125% of operating power to support 10-minute heartbeats.

0-20 Amp CT Specifications

Absolute max CT current	50 Amps RMS (A rms)
Maximum accurate CT current	20 A rms
Frequency range	50–100 Hz
Accuracy	+/- (2% + .07 A rms)**
Calibrated accuracy with appropriate offset	+/- (1% + .035 A rms)**
Offset limits	-1.27 to + 1.27 A rms (default set to +0.1 A rms) ***
Measurement resolution	~.01 A rms
Typical Deadband	~0.1 A rms ***
Current transducer dimensions	40 mm x 25 mm x 26 mm (10 mm inner diameter)
Weight	2.10 ounces
Lead Length	3 feet

0-150 Amp CT Specifications

Absolute max CT current	200 Amps RMS (A rms)
Maximum accurate CT current	150 A rms
Frequency range	50–100 Hz
Accuracy	+/- (2% + .4 A rms)**
Calibrated accuracy with appropriate offset	+/- (1% + .2 A rms) **
Offset limits	-1.27 to + 1.27 A rms (default set to + 0.3 A rms) ***
Measurement resolution	~0.1 A rms
Typical Deadband	~0.3 A rms***
Current transducer dimensions	67 mm x 49 mm x 42 mm (24 mm inner diameter)
Weight	7.27 ounces
Lead Length	3 feet

* CTs are inherently less accurate at or below 10% of max range. For best calibration results calibrate at a current between 30% and 90% of max accurate range.

** Offset is used to overcome a diode voltage drop inherent to the hardware. To accurately account for this drop a default offset is used. To best identify the optimal value of this offset make a series of measurements at 0.2 to 2 Arms and find the current (Arms) difference between your measurement standard and the sensor.

Commercial Grade Sensors

Commercial grade sensors are designed for applications in ordinary environments (normal room temperature, humidity and atmospheric pressure). Do not use these sensors under the following conditions as these factors can deteriorate the product characteristics and cause failures and burnout. Corrosive gas or deoxidizing gas: chlorine gas, hydrogen sulfide gas, ammonia gas, sulfuric acid gas, nitric oxides gas, etc. Volatile or flammable gas. Dusty conditions. Low-pressure or high-pressure environments. Wet or excessively humid locations. Places with salt water, oils chemical liquids or organic solvents. Where there are excessively strong vibrations. Other places where similar hazardous conditions exist.

Use these products within the specified temperature range. Higher temperature may cause deterioration of the characteristics or the material quality.

Industrial Grade Sensors | Type 1, 2, 4, 4X, 12 and 13 NEMA Rated Enclosure

Industrial sensors are enclosed in reliable, weatherproof NEMA-rated enclosures. Our NEMA-rated enclosures are constructed for both indoor or outdoor use and protect the sensor circuitry against the ingress of solid foreign objects like dust as well as the damaging effects of water (rain, sleet, snow, splashing water, and hose-directed water).

- Safe from falling dirt
- Protects against wind-blown dust
- Protects against rain, sleet, snow, splashing water, and hose-directed water
- Increased level of corrosion resistance
- Will remain undamaged by ice formation on the enclosure