



Wireless Water Rope Sensor

General Description

The Wireless Water Rope Sensor detects the presence of water anywhere along the surface of the rope. The Sensor comes with 10 feet of water rope. Additional 10ft. sections are available and can be connected up to 100 feet.

- 10 ft. lead and 10 ft. water detection rope.
- Immediately detects water anywhere along rope.
- Expandable up to 100 ft. of detection rope.



Online wireless sensor monitoring and notification system to configure sensors, view data and set alerts via SMS text and email.

Principle of Operation

The Wireless Water Rope Sensor detects water anywhere along the length of the detection rope by using two wires covered with conducting polymer. When water contacts the rope, the sensor immediately turns on the RF radio and transmit the data to the wireless gateway and Online Sensor Monitoring and Notification System, allowing the user to immediately receive an alert by SMS text, email or voice call. The sensor rope dries quickly allowing the sensor to reset for next use. Detection rope can be expanded up to 100 feet by simply clicking additional 10 foot sections of detection rope together.

Example Applications

- Data center and server room water monitoring.
- Document retention center monitoring.
- Basement water monitoring.
- Plumbing leak detection.
- Boat bilge monitoring.
- Storage monitoring.

Sensor Core Specifications

- Wireless Range: 250 - 300 ft. (non-line-of-sight / indoors through walls, ceilings & floors) *
- Communication: RF 900, 920, 868 and 433 MHz
- Power: Replaceable batteries (optimized for long battery life) - Line-power (AA version) options are available
- Battery Life (at 1 hour heartbeat setting): **
AA battery > 4-8 years

- * Actual range may vary depending on environment.
- ** Battery life is determined by sensor reporting frequency and other variables.

Wireless Water Rope Sensor (AA)

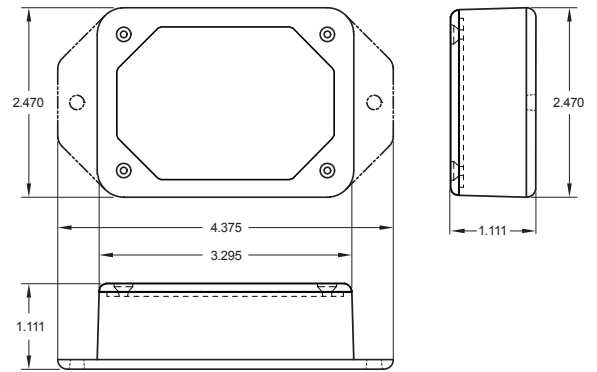

Technical Specifications

Supply Voltage	.0 - 3.6 VDC (3.0 - 3.6 VDC Using Power Supply) *
Current Consumption	0.7 μ A (sleep mode after measurement) 2 mA (radio idle/off mode) 2 mA (measurement mode) 25 mA (radio RX mode) 35 mA (radio TX mode)
Operating Temperature Range (Board Circuitry and Batteries)	-18°C to 55°C (0°F to 130°F) using alkaline -40°C to 85°C (-40°F to 185°F) using lithium **
Optimal Battery Temperature Range (AA)	+10°C to +50°C (+50°F to +122°F)
Weight	9.0 oz.
Wireless Range	250 - 300 ft. (Indoors / Through walls, ceilings & floors) Range may vary according to environmental variables.
Certifications	900 MHz product; FCC ID: ZTL- RFSC1 and IC: 9794A-RFSC1. 920 MHz product; ARIB STD-T108 R210-103733. 868 and 433 MHz product tested and found to comply with: CISPR 22:2008-09 / EN 55022:2010 - Class B and ETSI EN 300 220-2 V2.4.1 (2012-05).



Water Detection Rope Specifications

Material	PE + alloy lead
Weight	30g/meter
Pull Force Limit	60kg
Fire Resistance	Second pressure plenum cable
Cable Diameter	5.5mm
Core Resistance	3ohm/100 meters
Maximum Exposed Temperature	75°C (167°F)
Cable length	10 ft. (120 in.) included (expandable to 100 ft.)

Options

Commercial Grade Sensors

Commercial grade sensors are designed for applications in ordinary environments (normal room temperature, humidity and atmospheric pressure). Do not use these sensors under the following conditions as these factors can deteriorate the product characteristics and cause failures and burn-out.

- Corrosive gas or deoxidizing gas - chlorine gas, hydrogen sulfide gas, ammonia gas, sulfuric acid gas, nitric oxides gas, etc.).
- Volatile or flammable gas.
- Dusty conditions.
- Under low or high pressure.
- Wet or excessively humid locations.
- Places with salt water, oils chemical liquids or organic solvents.
- Where there are excessively strong vibrations.
- Other places where similar hazardous conditions exist.

Use these products within the specified temperature range. Higher temperature may cause deterioration of the characteristics or the material quality.

Industrial Grade Sensors - Type 1, 2, 4, 4X, 12 and 13 NEMA Rated Enclosure

Industrial sensors are enclosed in reliable, weatherproof NEMA rated enclosures. Our NEMA rated enclosures are constructed for both indoor or outdoor use and protect the sensor circuitry against the ingress of solid foreign objects like dust as well as the damaging effects of water (rain, sleet, snow, splashing water, and hose directed water).

- Safe from falling dirt.
- Protects against wind-blown dust.
- Protects against rain, sleet, snow, splashing water, and hose directed water
- Increased level of corrosion resistance
- Will remain undamaged by ice formation on the enclosure