

# Wireless Motion Detection Sensor

## General Description

The wireless motion detection sensor uses an infrared sensor to accurately detect movements made by people/ animals within 16.4 ft (5 m) range.

## Features

- Detects motion.



Online wireless sensor monitoring and notification system to configure sensors, view data and set alerts via SMS text and email.

## Principle of Operation

The Wireless Motion Detection Sensor detects motion and movement using infrared technology. When the sensor detects movement it communicates with the Online Sensor Monitoring and Notification System. BZ-COM stores all data in the online system where the data can be reviewed and exported as a data sheet or graph. Notifications can be set up through the online system to alert the user when motion has been detected.

## Example Applications

- Monitor area access.
- Detect when people enter a room.

And many more...

## Sensor Core Specifications

- Wireless Range: 250 - 300 ft. (non-line-of-sight / indoors through walls, ceilings & floors) \*
- RF Communication: 900, 920, 868 and 433 MHz
- Power: Replaceable batteries (optimized for long battery life, line-power and solar (Industrial only) options are available)
- Battery Life (at 1 hour heartbeat setting): \*\*

AA battery > 4-8 years

\*\* Battery life is determined by sensor reporting frequency and other variables.

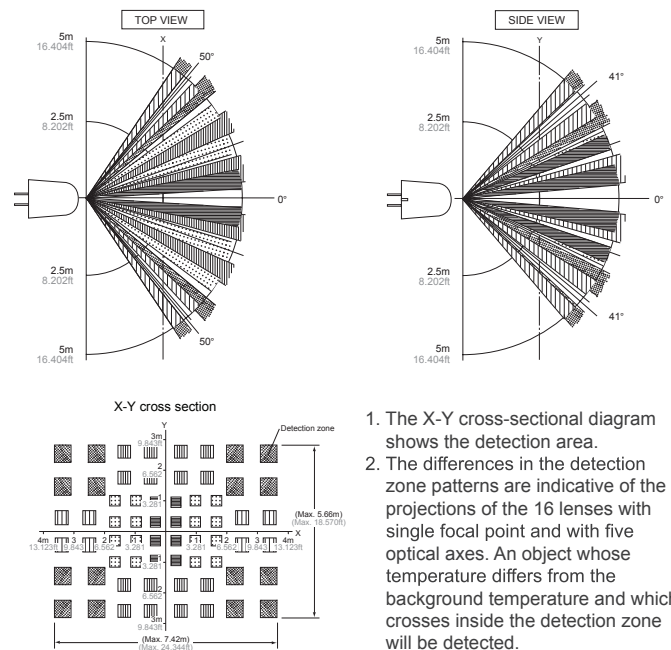

## Wireless Motion Detection Sensor (AA)

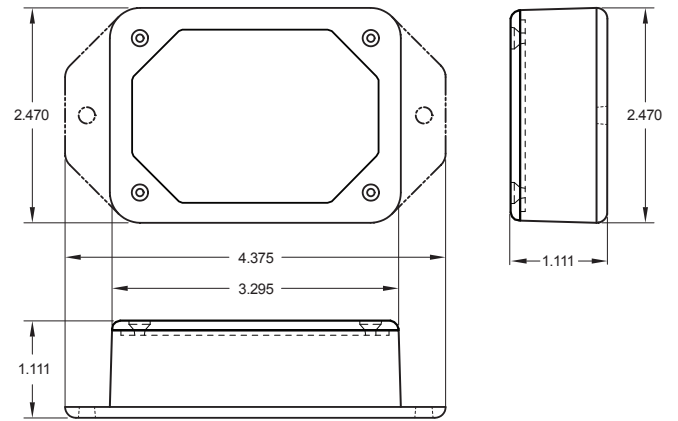

### Technical Specifications

Supply Voltage	2.0 - 3.6 VDC (3.0 - 3.6 VDC Using Power Supply) *
Current Consumption	0.7 $\mu$ A (sleep mode) 2 mA (radio idle/off mode) 2 mA (measurement mode) 25 mA (radio RX mode) 35 mA (radio TX mode)
Operating Temperature Range (Board Circuitry and Batteries)	-18°C to 55°C (0°F to 130°F) using alkaline -40°C to 85°C (-40°F to 185°F) using lithium **
Optimal Battery Temperature Range (AA)	+10°C to +50°C ( +50°F to +122°F )
Sensor Detection Range	16.4 ft (5 m)
Reted Consumption Current (Standby)	Typ: 170 $\mu$ A Max: 300 $\mu$ A
Sensor Warmup Time	30 Seconds
Weight	3.7 Ounces
Wireless Range	250 - 300 ft. (Through walls, ceilings and floors) Range may vary according to environmental variables
Certifications	900 MHz product; FCC ID: ZTL- RFSC1 and IC: 9794A- RFSC1. 920 MHz product; ARIB STD-T108 R210- 103733. 868 and 433 MHz product tested and found to comply with: CISPR 22:2008-09 / EN 55022:2010 - Class B and ETSI EN 300 220-2 V2.4.1 (2012-05).



## Notes

### Commercial Grade Sensors

Commercial grade sensors are designed for applications in ordinary environments (normal room temperature, humidity and atmospheric pressure). Do not use these sensors under the following conditions as these factors can deteriorate the product characteristics and cause failures and burn-out.

- Corrosive gas or deoxidizing gas - chlorine gas, hydrogen sulfide gas, ammonia gas, sulfuric acid gas, nitric oxides gas, etc.).
- Volatile or flammable gas.
- Dusty conditions.
- Under low or high pressure.
- Wet or excessively humid locations.
- Places with salt water, oils chemical liquids or organic solvents.
- Where there are excessively strong vibrations.
- Other places where similar hazardous conditions exist.

Use these products within the specified temperature range. Higher temperature may cause deterioration of the characteristics or the material quality.