



## Wireless Temperature Sensor

### General Description

The Wireless Temperature Sensor uses a type NTC thermistor to measure temperature.

### Features

- Accurate to  $\pm 1^{\circ}\text{C}$  ( $\pm 1.8^{\circ}\text{F}$ ).
- Increased accuracy by user calibration to  $\pm 0.25^{\circ}\text{C}$  ( $\pm 0.45^{\circ}\text{F}$ ).



Online wireless sensor monitoring and notification system to configure sensors, view data and set alerts via SMS text and email.

### Principle of Operation

The Wireless Temperature Sensor outputs the ambient temperature in degrees Fahrenheit. It is programmed to sleep for a user-given time interval (heartbeat) and then wakeup, send power to the NTC Thermistor and wait for it to stabilize, and convert the analog data, mathematically compute the temperature and transmit the data to the gateway. To stay within the abilities of the processor, the temperature is computed off a data table provided by the manufacturer. To reduce error, a variable resistor configuration is implemented over specified temperature ranges.

### Example Applications

- Ambient Temperature Monitoring
- Environmental Monitoring
- Smart Machines & Smart Structures
- HVAC Operation & Testing
- Data Center Monitoring

And many more...

### Sensor Core Specifications

- Wireless Range: 250 - 300 ft. (non-line-of-sight / indoors through walls, ceilings & floors) \*
- RF Communication: 900, 920, 868 and 433 MHz
- Power: Replaceable batteries (optimized for long battery life, line-power and solar (Industrial only) options are available)
- Battery Life (at 1 hour heartbeat setting): \*\*

AA battery > 4-8 years  
Industrial > 4-8 years

\*\* Battery life is determined by sensor reporting frequency and other variables.

## Wireless Temperature Sensor (AA)

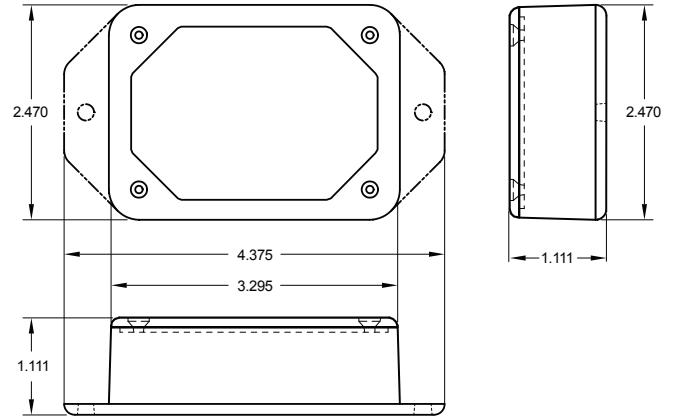

### Technical Specifications

Supply Voltage	2.0 - 3.6 VDC (3.0 - 3.6 VDC Using Power Supply) *
Current Consumption	0.7 $\mu$ A (sleep mode) 2 mA (radio idle/off mode) 2 mA (measurement mode) 25 mA (radio RX mode) 35 mA (radio TX mode)
Operating Temperature Range (Board Circuitry and Batteries)	-18°C to 55°C (0°F to 130°F) using alkaline -40°C to 85°C (-40°F to 185°F) using lithium **
Optimal Battery Temperature Range (AA)	+10°C to +50°C (+50°F to +122°F)
Thermistor Temperature Range (Thermistor Only)	-40°C to +125°C (-40°F to +257°F) (Limited to Main Unit Circuitry, -7°C to +60°C unless thermistor leads are being used.)
Accuracy @ 25°C	+/- 1% (1° C or 1.8° F)
User Calibrated Accuracy	+/- 0.25° C ( $\pm$ 0.45° F)
Time Constant @ 25°C	15 sec max
Weight	3.6 oz. (3.7 oz w/ 3' probe)
Wireless Range	250 - 300 ft. (Through walls, ceilings and floors) Range may vary according to environmental variables
Certifications 	900 MHz product; FCC ID: ZTL- RFSC1 and IC: 9794A-RFSC1. 920 MHz product; ARIB STD-T108 R210-103733. 868 and 433 MHz product tested and found to comply with: CISPR 22:2008-09 / EN 55022:2010 - Class B and ETSI EN 300 220-2 V2.4.1 (2012-05).

## Wireless Temperature Sensor (Industrial)

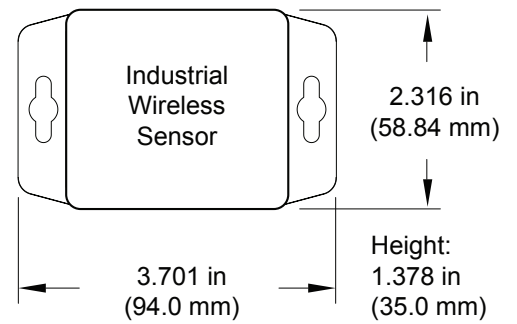

### Technical Specifications

Supply Voltage	2.0 - 3.6 VDC *	
Current Consumption	0.7 $\mu$ A (sleep mode) 2 mA (radio idle/off mode) 2 mA (measurement mode) 25 mA (radio RX mode) 35 mA (radio TX mode)	
Operating Temperature Range (Board Circuitry and Battery)		
Included Battery	Max Temperature Range:	-40°C to +85°C ( -40°F to +185°F ) **
	Capacity:	1500 mAh
Optional Solar Feature	Solar Panel:	5VDC / 30mA (53mm x 30mm)
	Charging Temperature Range:	0° to 45°C (32° to 113°F)
	Max Temperature Range:	-20° to 60°C (-4° to 140°F)
	Included Rechargeable Battery:	600 mAh / >2000 Charge Cycles (80% of initial capacity)
	Charging efficiency	5% ***
	Luminous sustainability	Minimum of 10,000 LUX ***
Thermistor Temperature Range (Thermistor Only)	-40°C to +125°C ( -40°F to +257°F ) ( Limited to Main Unit Circuitry, -40°C to +85°C )	
Accuracy @ 25°C	+/- 1% (1° C or 1.8° F)	
User Calibrated Accuracy	+/- 0.25° C (± 0.45° F)	
Time Constant @ 25°C	30 sec	
Enclosure Rating	NEMA 1, 2, 4, 4x, 12 and 13 rated, sealed and weather proof	
UL Rating	UL Listed to UL508-4x specifications (File E194432)	
Weight	4.7 oz	
Wireless Range	250 - 300 ft. (Through walls, ceilings and floors) Range may vary according to environmental variables.	
Certifications	 900 MHz product; FCC ID: ZTL- RFSC1 and IC: 9794A-RFSC1. 920 MHz product; ARIB STD-T108 R210-103733. 868 and 433 MHz product tested and found to comply with: CISPR 22:2008-09 / EN 55022:2010 - Class B and ETSI EN 300 220-2 V2.4.1 (2012-05).	

## Notes

### Commercial Grade Sensors

Commercial grade sensors are designed for applications in ordinary environments (normal room temperature, humidity and atmospheric pressure). Do not use these sensors under the following conditions as these factors can deteriorate the product characteristics and cause failures and burn-out.

- Corrosive gas or deoxidizing gas - chlorine gas, hydrogen sulfide gas, ammonia gas, sulfuric acid gas, nitric oxides gas, etc.).
- Volatile or flammable gas.
- Dusty conditions.
- Under low or high pressure.
- Wet or excessively humid locations.
- Places with salt water, oils chemical liquids or organic solvents.
- Where there are excessively strong vibrations.
- Other places where similar hazardous conditions exist.

Use these products within the specified temperature range. Higher temperature may cause deterioration of the characteristics or the material quality.

### Industrial Grade Sensors - Type 1, 2, 4, 4X, 12 and 13 NEMA Rated Enclosure

Industrial sensors are enclosed in reliable, weatherproof NEMA rated enclosures. Our NEMA rated enclosures are constructed for both indoor or outdoor use and protect the sensor circuitry against the ingress of solid foreign objects like dust as well as the damaging effects of water (rain, sleet, snow, splashing water, and hose directed water).

- Safe from falling dirt.
- Protects against wind-blown dust.
- Protects against rain, sleet, snow, splashing water, and hose directed water
- Increased level of corrosion resistance
- Will remain undamaged by ice formation on the enclosure